

## 2017 TECHNICAL REGULATIONS

Revision Date: **April 5, 2017**



**P3**

Series:

### IMSA PROTOTYPE CHALLENGE

Presented by Mazda

Class:

**LMP3**



Sanctioned by:

**INTERNATIONAL  
MOTOR SPORTS  
ASSOCIATION**

One Daytona Blvd.  
Daytona Beach, FL 32114  
(O) +1 (386) 310-6500  
(F) +1 (386) 310-6695  
[www.imsa.com](http://www.imsa.com)

## Table of Contents

<b>ARTICLE 1. DEFINITIONS SPECIFIC TO THE TECHNICAL REGULATIONS</b> .....	<b>3</b>	9.2. Modifications to the Specification.....	11
<b>ARTICLE 2. TECHNICAL PHILOSOPHY</b> .....	<b>4</b>	9.3. Servicing, Repair, and Replacement.....	11
2.1. Technical Eligibility.....	4	9.4. Dimensions.....	12
2.2. Balance of Performance Adjustment.....	4	9.5. Chassis.....	12
2.3. Changes.....	4	9.6. Driver Interface.....	12
<b>ARTICLE 3. USING THESE TECHNICAL REGULATIONS</b> .....	<b>4</b>	9.7. Bodywork.....	13
3.1. Structure.....	4	9.8. Aerodynamic Elements.....	13
3.2. Conflict Resolution.....	5	9.9. Engine System.....	13
3.3. Final Authority.....	5	9.10. Boost Management.....	13
<b>ARTICLE 4. HOMOLOGATION</b> .....	<b>5</b>	9.11. Drive System.....	13
4.1. Homologation Regulations.....	5	9.12. Cooling System.....	14
4.2. Homologation Process.....	5	9.13. Fuel System.....	14
4.3. Homologation Files and Documentation.....	5	9.14. Brake System.....	14
4.4. Homologation Inspection.....	6	9.15. Steering System.....	15
4.5. Homologation Testing.....	6	9.16. Suspension System.....	15
4.6. Homologation Identifier.....	6	9.17. Wheels & Tires.....	15
4.7. Conditions for Use of a Specific Homologation.....	6	9.18. Electronics.....	15
<b>ARTICLE 5. TECHNICAL ELIGIBILITY</b> .....	<b>7</b>	<b>ARTICLE 10. SERIES REQUIRED ELECTRONICS</b> .....	<b>16</b>
5.1. Technical Credential Process.....	7	10.1. Series Scrutineering Data System.....	16
5.2. Technical Credential Files and Documentation.....	7	10.2. Safety Light System.....	16
5.3. Technical Eligibility Testing.....	7	10.3. Transponder System.....	18
5.4. Technical Credential Identifier.....	8	10.4. X2 Transponder System.....	18
5.5. Conditions for Use of Specific Technical Credential.....	8	10.5. Leader Light System.....	18
<b>ARTICLE 6. BALANCE OF PERFORMANCE</b> .....	<b>8</b>	10.6. Back-lit Panel.....	18
6.1. Balance of Performance.....	8	10.7. Pro-Am Light.....	18
<b>ARTICLE 7. SAFETY</b> .....	<b>8</b>	10.8. In-Car Camera.....	18
7.1. Driver Safety Harness System.....	8	<b>ARTICLE 11. REFUELING SYSTEM</b> .....	<b>18</b>
7.2. Seat.....	8	11.1. Fuel Transfer.....	18
7.3. Driver Containment Nets.....	9	11.2. Pit Tank.....	18
7.4. Protective Padding.....	9	11.3. Peripheral Connections.....	18
7.5. Protective Shielding.....	9	11.4. Refueling Hose.....	19
7.6. Master Electrical Switches.....	9	11.5. Trolley.....	19
7.7. Fire Suppression System.....	10	11.6. Boom.....	19
<b>ARTICLE 8. DEFINITION OF CLASS</b> .....	<b>11</b>	11.7. Refueling Restrictor.....	19
8.1. LMP3.....	11	11.8. Level Sensor System.....	19
<b>ARTICLE 9. VEHICLE SYSTEMS</b> .....	<b>11</b>		
9.1. General.....	11		

## ARTICLE 1. DEFINITIONS SPECIFIC TO THE TECHNICAL REGULATIONS

- 1.1.1. **Car** means a singular representation of a Car Model possessing a Technical Credential, entered by an Entrant in an Event.
- 1.1.2. **Car Model** means a specific model of a vehicle constructed by an IMSA-recognized Manufacturer Partner, and intended for Competition.
- 1.1.3. **Class** means a category for Cars sharing a common set of Homologation Regulations and differentiated from others by type of Car Model.
- 1.1.4. **Competition** means a contest of competitive nature in which a Car takes part during an Event and results of which Competition are published.
- 1.1.5. **Constructor** means an entity that designs and builds race car chassis.
- 1.1.6. **Entrant** means an entity or person who has entered a Car that has been accepted for Competition and holds an IMSA Membership in the capacity of an Entrant or Entrant/Driver.
- 1.1.7. **Event** means an IMSA Sanctioned motorsport activity. It includes the designated Race as well as all periods for registration, inspections, practice Sessions, qualifying Sessions, racing, pre- and post-Race activities and inspections, and rain or postponed dates related thereto.
- 1.1.8. **Homologate** means to execute the Homologation Process.
- 1.1.9. **Homologated** means a Car Model approved through the Homologation Process.
- 1.1.10. **Homologation** means the concept of all things associated with Homologation Authority approval via the Homologation Process.
- 1.1.11. **Homologation Authority** means an entity with the authority to Homologate.
- 1.1.12. **Homologation Documentation** means all files, documents, information, and communication associated with the issuance of official approval of Homologation.
- 1.1.13. **Homologation Identifier** means the unique identifier (generally including a string of characters identifying the Category or Class of Homologation followed by a sequential number assigned to the Car Model) serving as a reference to the official approval of Homologation, assigned by the Homologation Authority.
- 1.1.14. **Homologation Process** means all procedures associated with petitioning a Homologation Authority for approval that a Car Model complies with the Homologation Regulations.
- 1.1.15. **Homologation Regulations** means a set of technical requirements and criteria used to design, construct, and document a Car Model intended for racing in a specific category or class of racing.
- 1.1.16. **Manufacturer** means a Manufacturer Partner constructing an approved Car Model.
- 1.1.17. **Manufacturer Partner** means a recognized IMSA Official Automotive Partner.
- 1.1.18. **Permissive** means modifications explicitly authorized by these Technical Regulations are permitted and modifications not explicitly authorized by these Technical Regulations are prohibited.
- 1.1.19. **Specification** means all technical characteristics of the Car Model defined by the Homologation and Technical Credential.
- 1.1.20. **Specific Homologation** means the Homologation specific to a particular Car Model.
- 1.1.21. **Specific Technical Credential** means the Technical Credential specific to a particular Car Model.
- 1.1.22. **Technical Credential** means the concept of all things associated with IMSA approval via the Technical Credential Process.
- 1.1.23. **Technical Credential Documentation** means all files, documents, information, and communication associated with the Technical Credential Process.
- 1.1.24. **Technical Credential Identifier** means the unique identifier that serves as a reference to the Technical Credential granted by the IMSA. Example: IMSA GTLM 20170101 [GTE-0XX].

- 1.1.25. **Technical Credential Process** means all procedures associated with petitioning IMSA for approval that a Car Model is Technically Eligible.
- 1.1.26. **Technical Eligibility Form** means the form which documents the Specific Technical Credential.
- 1.1.27. **Technically Eligible** means conforms to all technical requirements and criteria defined by these Technical Regulations.

## ARTICLE 2. TECHNICAL PHILOSOPHY

### 2.1. Technical Eligibility

- 2.1.1. Car Models Technically Eligible for participation in IMSA Events are issued a Technical Credential Identifier.
- 2.1.2. Cars representing a Car Model must always respect the Specification.
- 2.1.3. To be issued a Technical Credential Identifier for participation in this Class, a Car Model must:
  - a. Be a Car Model constructed by an IMSA-recognized Manufacturer Partner.
  - b. Hold a valid Homologation conforming to the Homologation Regulations and Homologation Documentation specific to the Class, approved and issued by an IMSA-recognized Homologation Authority.
  - c. Successfully complete the IMSA Technical Credential Process.
- 2.1.4. IMSA is the sole authority to define the Technical Eligibility of a Car Model and issue the Technical Credential.

### 2.2. Balance of Performance Adjustment

- 2.2.1. N/A

### 2.3. Changes

- 2.3.1. Changes to the Specification are prohibited, unless explicitly authorized by IMSA.
- 2.3.2. Manufacturers alone must petition IMSA to change the Specification; requests by Entrants are not recognized.

## ARTICLE 3. USING THESE TECHNICAL REGULATIONS

### 3.1. Structure

- 3.1.1. These Technical Regulations are structured to assist Manufacturers and Entrants in accurate interpretation of the technical expectations and enforcement of the IMSA Technical Philosophy.
  - a. A brief description of each Article and its purpose follows:

Article / Name	Description / Purpose
1. Definitions Specific to the Technical Regulations	Standardized meanings for specific terms of these Technical Regulations.
2. Technical Philosophy	Guiding principles for these Technical Regulations.
3. Using These Technical Regulations	General structure, purpose, and clarifying statements for these Technical Regulations.
4. Homologation	Pertinent topics related to Homologation.
5. Technical Eligibility	Pertinent topics related to Technical Eligibility.
6. Balance of Performance	General processes associated with competitive equivalency.
7. Safety	Regulatory requirements associated with mandatory safety systems.
8. Definition of Class	Statement of specific Class, Homologation, and Technical Eligibility requirements.
9. Series Required Electronics	Regulatory requirements associated with mandatory electronic systems.
10. Vehicle Systems	Approved modifications to the Homologation component of the Car Model Specification.
11. Refueling System	Regulatory requirements associated with specified refueling system.

### 3.2. Conflict Resolution

- 3.2.1. These IMSA Technical Regulations shall govern in any case where a conflict exists with the Homologation Regulations and Documentation.

### 3.3. Final Authority

- 3.3.1. IMSA is the Final Authority with respect to these Technical Regulations.

## ARTICLE 4. HOMOLOGATION

---

### 4.1. Homologation Regulations

- 4.1.1. Reference to the official Homologation Regulations defining the requirements applicable to these Technical Regulations is provided in ARTICLE 8. DEFINITION OF CLASS.

### 4.2. Homologation Process

- 4.2.1. The procedures of the Homologation Process are used to verify that the Car Model meets the necessary requirements and criteria defined by the official set of Homologation Regulations.
- 4.2.2. This process generally includes the following components or phases, which must be completed to the satisfaction of the Homologation Authority:
- Homologation Files and Documentation
  - Homologation Inspection
  - Homologation Testing
  - Final Approval
  - Identification Assignment
- 4.2.3. Homologation Process fees may apply.

### 4.3. Homologation Files and Documentation

- 4.3.1. All files and documents required by the Homologation Authority to support the Homologation Process; including but not limited to:
- Basic Homologation Form
  - Homologation Extension Form(s)
  - Data Sheet(s)
  - CAD Models and Drawings
  - Logged Vehicle Data
  - Homologation Testing Data
- 4.3.2. Basic Homologation Form: Documents how the Car Model complies with the Homologation Regulations; including photographs, drawings, descriptions, and measurements defining the characteristics, components, parameters, and/or dimensions and tolerances for:
- General Vehicle
  - Specific Vehicle Systems
  - System Assemblies, Parts and Components
  - Modifications to the Original Series Production Car (if applicable)
- 4.3.3. Homologation Extension Forms: Describe all approved modifications made to the Basic Homologation Form, including but not limited to modifications for:
- Correction of incorrect information
  - Safety reasons
  - Reliability reasons
  - Evolutions of type introduced on the original Car Model (if applicable)
  - Evolutions for new components and/or characteristics that cancel and replace those featured in the original Basic Homologation Form
  - Variant options, such as endurance packages

- 4.3.4. CAD Models and Drawings: As required by the Homologation Authority to support the Homologation Process; including but not limited to:
  - a. Complete Vehicle CAD Models
  - b. Specific Component CAD Models
  - c. Specific Component Drawings
  - d. Engine Air Intake Restrictor(s)
- 4.3.5. Homologation Testing Data: Information, documentation, data, and results from Homologation Testing.

#### **4.4. Homologation Inspection**

- 4.4.1. The inspection process for drawings, CAD models, any reference component, and the constructed Car Model by the Homologation Authority.
  - a. These inspections confirm that a Car Model complies with the Homologation Regulations and are generally conducted as part of the following phases of the Homologation Process:
    - i. Design
    - ii. Construction
    - iii. Final Approval

#### **4.5. Homologation Testing**

- 4.5.1. Any testing conducted by the Homologation Authority to support the Homologation Process; including, but not limited to:
  - a. Straight-line Testing
  - b. Wind Tunnel Testing
  - c. Engine Dyno Testing
  - d. Track Testing

#### **4.6. Homologation Identifier**

- 4.6.1. The Homologation Identifier is electronically stamped/associated with all information, documentation and files associated with the Homologation.

#### **4.7. Conditions for Use of a Specific Homologation**

- 4.7.1. At all times during IMSA-sanctioned Events it is the Entrant's responsibility to ensure the configuration of the Car Model represents the Homologation components of the Specification; including:
  - a. As-Homologated Configuration
  - b. As-Delivered Configuration
  - c. Parts Manual
  - d. Homologation Extension Form Configuration
- 4.7.2. The original, As-Homologated Configuration of the Car Model must not be modified unless permitted by these Technical Regulations.
- 4.7.3. The As-Delivered Configuration of a Car must respect the as-received configuration from the Car Model Manufacturer, unless permitted by these Technical Regulations.
- 4.7.4. The Parts Manual is the official parts catalogue for the Car Model as defined by the Car Model Manufacturer or Constructor:
  - a. Specific parts listed in the Parts Manual must be used on all representations of a Car Model unless permitted by these Technical Regulations.
- 4.7.5. To be eligible for use in any IMSA-sanctioned Event, modifications detailed in Homologation Extension Forms must:
  - a. Comply with these Technical Regulations.
  - b. Be approved by, or have initiated the process to obtain approval from, the Homologation Authority, and appended to the Car Model Homologation.
  - c. Be approved by IMSA.

## ARTICLE 5. TECHNICAL ELIGIBILITY

---

### 5.1. Technical Credential Process

- 5.1.1. Manufacturers may begin the Technical Credential Process for a Car Model provided the Car Model:
  - a. Holds, or have initiated the process to obtain approval from, a valid Homologation as defined in these Technical Regulations.
  - b. Is approved by IMSA.
- 5.1.2. The procedures of the Technical Credential Process are used to verify that the Car Model meets the necessary requirements and criteria defined by these Technical Regulations.
- 5.1.3. This process generally includes the following components or phases, which must be completed to the satisfaction of IMSA:
  - a. Technical Credential Files and Documentation
  - b. Technical Eligibility Testing
  - c. Final Approval
  - d. Identification Assignment
- 5.1.4. IMSA may request Manufacturers submit reference components to support the Technical Credential process.
  - a. IMSA may retain these components without compensation.
- 5.1.5. IMSA may request Manufacturers submit reference tooling and/or templates to support the Technical Inspection process.
- 5.1.6. Technical Credential fees may apply.

### 5.2. Technical Credential Files and Documentation

- 5.2.1. All files and documents required by IMSA to support the Technical Credential Process; including but not limited to:
  - a. Technical Eligibility Form
  - b. Data Sheet(s)
  - c. CAD Models and Drawings
  - d. Logged Vehicle Data
  - e. Electronic Controller Calibrations
  - f. Technical Eligibility Testing Data
- 5.2.2. Technical Eligibility Form: Documents how the Car Model complies these Technical Regulations; including:
  - a. List of all files and documentation associated with the Specific Homologation of the Car Model
  - b. List of all files and documentation associated with the Specific Technical Credential of the Car Model
  - c. All approved IMSA-Only Declarations
- 5.2.3. CAD Models and Drawings: As required by IMSA to support the Technical Credential Process; including but not limited to:
  - a. Complete Vehicle CAD Models
  - b. Specific Component CAD Models
  - c. Specific Component Drawings
  - d. Additional components requested by IMSA
- 5.2.4. Technical Eligibility Testing Data: Information, documentation, data, and results from Technical Eligibility Testing.

### 5.3. Technical Eligibility Testing

- 5.3.1. Any testing conducted by IMSA to support the Technical Credential Process; including, but not limited to:
  - a. Restrictor Flow
  - b. Engine Dyno
  - c. Wind Tunnel
  - d. On-track Testing
  - e. Refueling Testing

#### 5.4. Technical Credential Identifier

- 5.4.1. The Technical Credential Identifier is electronically stamped/associated with all information, documentation and files associated with the Technical Credential.

#### 5.5. Conditions for Use of Specific Technical Credential

- 5.5.1. At all times during IMSA-sanctioned Events it is the Entrant's responsibility to ensure the configuration of the Car Model represents the approved Technical Credential components of the Specification.

### ARTICLE 6. BALANCE OF PERFORMANCE

---

#### 6.1. Balance of Performance

- 6.1.1. Not Applicable

### ARTICLE 7. SAFETY

---

#### 7.1. Driver Safety Harness System

- 7.1.1. Cars must be equipped with a minimum 6-point Driver safety harness with a valid label demonstrating compliance with one of the following standards:
- a. FIA Standard 8853/98: FIA Safety Harnesses Standard
    - i. [FIA Technical List #24](#): Harnesses Homologated by the FIA according to the FIA Standards 8853/98 and 8854/98
  - b. FIA Standard 8853-2016: Safety Harnesses
    - i. [FIA Technical List #57](#): Harnesses Homologated according to the FIA Standard 8853-2016
  - c. SFI Specification 16.5: Stock Car Driver Restraint Assemblies
    - i. [Specification](#)
    - ii. [Manufacturers](#)
  - d. SFI Specification 16.6: Advanced Motorsport Driver Restraint Assemblies
    - i. [Specification](#)
    - ii. [Manufacturers](#)
- 7.1.2. Installation must be performed in accordance with instructions provided by the system supplier and/or manufacturer.
- a. Belt components must be installed at each anchor point to prevent accidental release or opening.
  - b. Individual belt straps must be independent; any method or attempt to combine individual straps is prohibited.
  - c. Elastic retention straps are prohibited.
- 7.1.3. Harnesses must be replaced at the request of IMSA, or whenever the following conditions occur:
- a. Expiration:
    - i. FIA Homologated: Immediately following December 31<sup>st</sup> of the year printed on the label.
    - ii. SFI Certified: Immediately following December 31<sup>st</sup> two (2) years after the year of Manufacture.
  - b. Damage:
    - i. Following a severe collision.
    - ii. Webbing is cut or frayed, or weakened due to actions of chemicals or sunlight.
    - iii. Buckles are bent, deformed, rusted, or improperly functioning.
- 7.1.4. Entrants are responsible for ensuring the Driver safety harnesses and all associated components are properly labeled, installed, used, and maintained.

#### 7.2. Seat

- 7.2.1. Cars must be equipped with a seat with a valid label demonstrating compliance with one of the following standards:
- a. FIA Standard 8862-2009: Advanced Racing Seat



- i. [FIA Technical List #40](#): Advanced Racing Seats Homologated according to the FIA Standard 8862-2009
- b. FIA Standard 8855-1999: FIA Standard for Competition Seats
  - i. [FIA Technical List #12](#): Seats Homologated on the Basis of the FIA Standard 8855-1999
- 7.2.2. Seat manufacturer written approval is required for seat modification.
- 7.2.3. Seats must be replaced at the request of IMSA, or prior to December 31<sup>st</sup> of the expiration year printed on the label.

### 7.3. Driver Containment Nets

- 7.3.1. Not Applicable

### 7.4. Protective Padding

- 7.4.1. Cars must be equipped with non-flammable protective padding with a valid label demonstrating compliance with one of the following standards:
  - a. FIA Standard 8857-2001: FIA Roll Cage Padding Standard
    - i. [FIA Technical List #23](#): Roll Cage Padding Homologated by the FIA
  - b. SFI Specification 45.1: Roll Cage Padding
    - i. [Specification](#)
    - ii. [Manufacturers](#)
- 7.4.2. Installation requirements:
  - a. Padding must be located to protect the Driver (body and/or helmet) against direct contact with the safety cage in a collision.
  - b. Protective padding must be securely affixed to prevent rolling or displacement.

### 7.5. Protective Shielding

- 7.5.1. Cars may be equipped with shielding to protect the Driver against contact with cockpit equipment in a collision.
- 7.5.2. Installation requirements:
  - a. Installations must not impact cockpit exit.
  - b. Installations must be approved by IMSA.

### 7.6. Master Electrical Switches

- 7.6.1. Cars must be equipped with interior and exterior master electrical switches.
- 7.6.2. Master electrical switches must be spark-proof, and when activated must:
  - i. De-energize all electrical circuits.
  - ii. Stop the engine.
- 7.6.3. The interior master switch must be installed within the cockpit, and located so the driver may activate the switch when seated in a normal position with safety belts fastened and steering wheel in place.
- 7.6.4. The exterior master switch must be installed proximal to the fire suppression control at (or near) the base of the left side A-Pillar.
  - a. Exterior master switch be located such that emergency responders may activate with a single action:
    - i. Using a gloved finger, or tools such as a hook.
    - ii. Unencumbered by bodywork, windshield wipers, or any equipment that may require multiple actions.
  - b. A method for preventing activation of the exterior master switch:
    - i. May be enabled when the Car is in Technical Inspection, in the Paddock, or located near large crowds, such as during pre-Race activities.
    - ii. Must be removed prior to participation in on-track activity.
- 7.6.5. Interior and exterior master switches must be clearly identified by a self-reflective symbol of a red spark surrounded by a white-edged, blue triangle with a base greater than 30 mm.

## 7.7. Fire Suppression System

- 7.7.1. Cars must be equipped with a fire extinguisher system with a valid label demonstrating compliance with one of the following standards:
  - a. FIA Standard for plumbed-in Fire Extinguisher Systems in Competition Cars (1999):
    - i. [FIA Technical List #16](#): Extinguisher Systems Homologated by the FIA
  - b. FIA Standard 8865-2015: Plumbed-in and Hand-Held Fire Extinguisher Systems
    - i. [FIA Technical List #52](#): Plumbed-in Fire Extinguisher Systems according to FIA Standard 8865-2015
  - c. SFI Specification 17.1: On Board Fire Suppression Systems
    - i. [Specification](#)
    - ii. [Manufacturers](#)
- 7.7.2. System must provide adequate fire protection for the driver's compartment, engine and fuel cell.
  - a. Extinguishing media must be compatible with all aspects and accessories of the fire suppression system.
  - b. IMSA recommends voluntary compliance with FIA 8865-2016.
    - i. Mandatory compliance with FIA 8865-2016 is anticipated for 2018.
  - c. All system components must be used and serviced per manufacturer specifications.
- 7.7.3. System must be securely mounted.
  - a. The following must be visible without the use of photography, tools, or seat removal:
    - i. Pressure gauge (if present)
    - ii. Date of manufacture
    - iii. Next required service date
  - b. Nozzles must not point directly at the Driver's face.
- 7.7.4. System must include an exterior activation mechanism proximal to the exterior master electrical switch at (or near) the base of the left side A-Pillar.
  - a. Exterior activation mechanism must be located such that emergency responders may activate with a single action:
    - i. Using a gloved finger, or tools such as a hook.
    - ii. Unencumbered by bodywork, windscreen wipers, or any equipment that may require multiple actions.
  - b. A method for preventing activation of the exterior activation mechanism:
    - i. May be enabled when the Car is in Technical Inspection, in the Paddock, or located near large crowds, such as during pre-Race activities.
    - ii. Must be removed prior to participation in on-track activity.
- 7.7.5. Identification
  - a. Exterior activation mechanism must be marked with a self-reflective symbol with a red edge surrounding a red "E" inside a white circle at least 100 mm in diameter.
- 7.7.6. Inspection
  - a. IMSA may require removal of the fire bottle for Technical Inspection.
  - b. Entrant is responsible to demonstrate proper system function of the interior and exterior fire suppression activation mechanisms, using the "test" mode if present.

## ARTICLE 8. DEFINITION OF CLASS

### 8.1. LMP3

- 8.1.1. Class Structure: LMP3 cars compete in the LMP3 Class of the IMSA MAZDA PROTOTYPE LIGHTS (IMPC).
- 8.1.2. Eligibility Requirements: To be eligible for participation in the Class, a Car Model must respect the Specification defined by the Homologation and Technical Eligibility requirements:
  - a. Homologation (LMP3):

<b>Homologation Authority:</b>	Automobile Club de l'Ouest (ACO)
<b>Homologation Specification:</b>	Automobile Club de l'Ouest (ACO) LMP3
<b>Homologation Regulations:</b>	2017 Technical Regulations for LMP3 Prototypes
<b>Additional Documentation:</b>	

## ARTICLE 9. VEHICLE SYSTEMS

### 9.1. General

- 9.1.1. All Vehicle Systems and associated sub-systems are listed in this Article.
  - a. Where change to these Vehicle Systems is permitted, regulatory text is **bold and underlined**.
  - b. Where change to these Vehicle Systems is prohibited, regulatory text is light grey.
  - c. Advisory statements are in normal text.

### 9.2. Modifications to the Specification

- 9.2.1. Entrants may execute the following changes to parameters defined by the Homologation component of the Car Model Specification, provided these Technical Regulations, all current Technical Bulletins, and the Technical Credential are fully respected:
  - a. Adjust component settings defined as adjustable.
  - b. Replace components with parts defined as optional.
- 9.2.2. Manufacturers must make any declarations listed in these Technical Regulations in the Technical Eligibility Form.
- 9.2.3. Further authorization to modify the Specification and/or As-Delivered Condition is granted via the following formal communication methods:
  - a. Published IMSA Technical Bulletin
  - b. Approved updates to the IMSA Technical Eligibility Form
- 9.2.4. Informal and/or verbal communication is not considered valid authorization.

### 9.3. Servicing, Repair, and Replacement

- 9.3.1. All servicing or repair must be made in good faith to restore the Car and all components to their originally intended form and function as defined by the Specification.
- 9.3.2. Entrants may replace damaged or worn components provided these Technical Regulations are respected.

## 9.4. Dimensions

### 9.4.1. General

### 9.4.2. Reference Surface

- a. The lowest plane of the underside of the car of the Car is measured to the Technical Inspection scale plane.

### 9.4.3. Mass

- a. The minimum mass for all Car Models is 930 kg.
- b. Car mass is measured as-raced minus Driver and Fuel using the IMSA scales during Technical Inspection.
- c. IMSA scales are the official scale of measurement.

### 9.4.4. Ballast

#### a. Entrants may add or remove ballast to achieve minimum mass:

- i. Ballast must be in plate or panel form.
- ii. Addition or removal of ballast during the race is prohibited.

#### b. Entrants using Cars without specific Homologated locations must:

- i. Locate all ballast inside the cockpit in the passenger's location.
- ii. Secure all ballast per FIA Article 253-16 in both dimensions and characteristics of fixation methods.
- iii. Design fixations such that tools are required for its removal.

### 9.4.5. Ground Clearance

### 9.4.6. Overall Dimensions

- a. Length
- b. Width
- c. Height
- d. Wheelbase
- e. Track
- f. Overhang
- g. Width

## 9.5. Chassis

### 9.5.1. General

#### a. Entrants may execute minimum modifications for the installation of components.

- i. All modifications must be approved by IMSA.

### 9.5.2. Air Jack System

## 9.6. Driver Interface

### 9.6.1. General

### 9.6.2. Steering Wheel

### 9.6.3. Pedal Box

#### a. Entrants may apply non-slip adhesives to the surface of driver pedals.

### 9.6.4. Shifting Mechanism

### 9.6.5. Driver Adjustable Components

### 9.6.6. Driver Cooling Systems

#### a. Entrants may install a maximum of two (2) Driver Cooling Systems, i.e. Cool Suits.

- i. Evaporative-loss Freon cool suits are prohibited.
- b. Installations must be approved by IMSA and meet the following conditions:

- i. The mounting location and installation for the primary system is unrestricted provided it serves no purpose other than retaining the cooling system in the event of a collision.
- ii. Any secondary driver cooling system must be mounted on the top of the ballast box.
- iii. All driver cooling system containers must be securely mounted.
- iv. The use of hook and loop fasteners (Velcro) is prohibited.

## 9.7. Bodywork

### 9.7.1. General

### 9.7.2. Bodywork Seams

- a. Entrants may apply tape over the body seams around refueling receptacles.

### 9.7.3. Decals

- a. Entrants may apply removable die cut sponsorship decals with the approval of IMSA.

## 9.8. Aerodynamic Elements

### 9.8.1. General

### 9.8.2. Splitter

### 9.8.3. Dive Planes

### 9.8.4. Body Gurney

### 9.8.5. Wings

### 9.8.6. Rear Wing Gurney

### 9.8.7. Floor

### 9.8.8. Friction Blocks

### 9.8.9. Diffuser

## 9.9. Engine System

### 9.9.1. General

- a. Manufacturer seals must be respected

### 9.9.2. Engine

### 9.9.3. Lambda

### 9.9.4. Engine RPM

### 9.9.5. Intake

### 9.9.6. Exhaust

### 9.9.7. Turbo

### 9.9.8. Engine Control Unit (ECU)

### 9.9.9. Engine Transportation Crate

- a. Entrant must have immediately available a crate sufficient to securely and safely package and ship an engine.

## 9.10. Boost Management

### 9.10.1. Maximum Boost Pressure

### 9.10.2. Boost Pressure Ratio

### 9.10.3. Boost Control Strategy Inputs

### 9.10.4. Calculation Method

## 9.11. Drive System

- 9.11.1. General
  - a. Manufacturer seals must be respected

- 9.11.2. Fluids & Lubricants

- a. **Unrestricted.**

- 9.11.3. Clutch
  - 9.11.4. Gearbox
  - 9.11.5. Gears
  - 9.11.6. Gearbox Control Unit
  - 9.11.7. Differential
  - 9.11.8. Axles
  - 9.11.9. Uprights

## 9.12. Cooling System

- 9.12.1. General
- 9.12.2. Fluids
  - a. **Entrants may utilize non-glycol based fluids.**
- 9.12.3. Inlet Blockers
- 9.12.4. Water System
- 9.12.5. Oil Cooling System

## 9.13. Fuel System

- 9.13.1. General
- 9.13.2. Fuel Types
  - a. The approved fuel for the Class is IMSA E10, as supplied by VP Fuels.
    - i. IMSA may require a fuel sample for inspection via a gas chromatograph.
- 9.13.3. Fuel Cell
- 9.13.4. Fuel Lines
- 9.13.5. Fuel Sample Port
  - a. **Entrants must equip the Car with the approved self-sealing connector for extraction of fuel samples:**
    - i. Approved Connector: Staubli P/N: CBI06.7251/IA/JKV.
    - ii. Must be located immediately before the injector nozzles.
    - iii. Installation must be approved by IMSA.
- 9.13.6. Refueling Receptacle

## 9.14. Brake System

- 9.14.1. General
- 9.14.2. Fluids & Lubricants
  - a. **Unrestricted.**
- 9.14.3. Bias Assembly
- 9.14.4. Master Cylinders
- 9.14.5. Brake Lines

9.14.6. Calipers

9.14.7. Rotors

9.14.8. Pads

- a. **Friction material is unrestricted.**
- b. Backing Plates must be ferrous.

9.14.9. Ducting

9.14.10. Brake Duct Inlet Blockers

- a. **Entrants may apply opaque adhesive tape to block off portions of the brake duct inlet openings.**

9.14.11. Anti-Lock Braking System

## 9.15. Steering System

9.15.1. General

9.15.2. Fluids & Lubricants

- a. **Unrestricted.**

## 9.16. Suspension System

9.16.1. General

9.16.2. Geometry Elements

9.16.3. Springs

9.16.4. Dampers

9.16.5. Bump Rubbers and Packers

- a. **Unrestricted.**

9.16.6. Anti-Roll Bar

9.16.7. Third Elements

## 9.17. Wheels & Tires

9.17.1. General

9.17.2. Wheels

9.17.3. Wheel Attachment

9.17.4. Tires

- a. The approved tire supplier for this Class is Continental Tire.

## 9.18. Electronics

9.18.1. General

9.18.2. Data Logger

- a. IMSA reserves the right to download and/or view all logged data at any time.

9.18.3. Telemetry

9.18.4. Wiring Loom

9.18.5. Sensors

9.18.6. Radio

- a. **Entrants may install a single two-way voice radio with car-to-pit communication capability in compliance with the corresponding Series Sporting Regulations.**

9.18.7. Rear View Camera

- a. **Where not homologated, Entrants may install a rear-view camera system.**

9.18.8. Auxiliary Power Sources

**ARTICLE 10. SERIES REQUIRED ELECTRONICS**

**10.1. Series Scrutineering Data System**

- 10.1.1. Cars must be equipped with an IMSA-supplied data logger when requested.
  - a. Cars must have a dedicated 12 V power lead to install the IMSA-supplied data logger.
  - b. Power lead shall remain on as long as the master kill is switch is on.

**10.2. Safety Light System**

- 10.2.1. Cars must be equipped with the Delphi Yellow Light Kit to indicate active flag status.
  - a. The Kit contains the following components:
    - i. Yellow Indicator Light
    - ii. Mounting Bracket
    - iii. Antenna
    - iv. Wiring Loom and Instructions
- 10.2.2. The Safety Light system must be installed and functioning during on-track activity.
  - a. The Yellow Indicator Light must be prominently installed within the cockpit, in clear line of sight of the driver.
  - b. Antenna Installation: The supplied antenna must be mounted:
    - i. On the Car roof
    - ii. Away from other antennae
    - iii. Following the diagram below (a ground plane is not required):

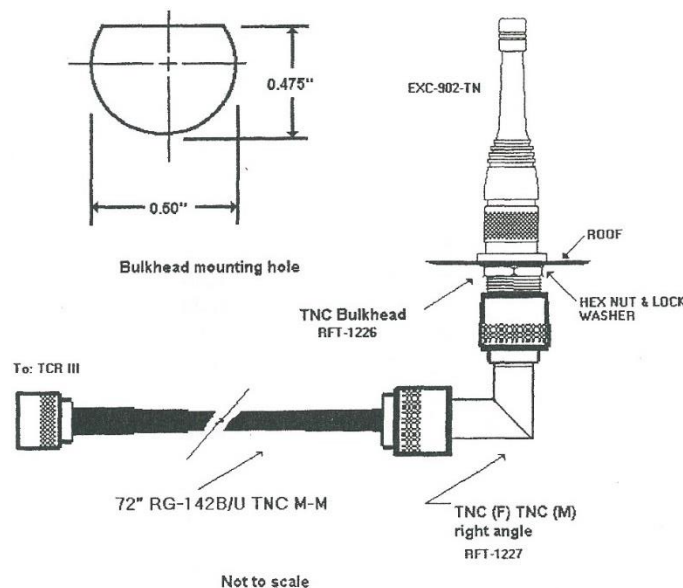

- c. Wiring Loom Installation: The Wiring Loom has a flying lead input for +12 VDC and Ground to interface with additional wiring referenced in the installation instructions.
  - i. Entrants must supply additional wiring as required.

10.2.3. An activating receiver is available from IMSA during Safety Checks at each Event and remains the property of IMSA.

- a. Entrants must surrender the receiver when required by IMSA.



- b. A lost or damaged receiver is subject to a replacement fee referenced in the IMSA Accessories form.

### 10.3. Transponder System

- 10.3.1. Cars must utilize MyLaps X2 or compatible (AMB TranX 260) transponder
  - a. Transponder must be mounted in the right front wheel well area
- 10.3.2. Transponder system must be installed and functioning during Events.
  - a. Outside interference must not exceed those levels commonly used in the automotive industry, as described in 95/54/EEG.
  - b. Transponder must be installed:
    - i. In a vertical orientation
    - ii. With appropriate thermal protection in an area where the temperature cannot exceed 50 °C
    - iii. Above non-conductive surfaces such as fiberglass or aramid panel
  - c. Transponder consumes less than 40 mA (10-30 VDC), and must:
    - i. Be a fused, 12-volt DC configuration
    - ii. Meet the specifications defined by ISO 7637
  - d. Transponder connection cables must be installed with appropriate thermal protection against temperatures exceeding:
    - i. Black Cables: 150 °C
    - ii. Blue Cables: 70 °C
  - e. In cases where the cable installation requires severing the transponder loom, the Entrant must:
    - i. Fit an appropriate connector
    - ii. Ensure the integrity of the system connectivity is always maintained
  - f. Entrant is responsible for replacing a lost or damaged Transponder.
    - i. Replacement cost is listed in the IMSA Accessories Order Form
- 10.3.3. Transponder and plugs must be tested and operate to the satisfaction of the Timing and Scoring Officials.

### 10.4. X2 Enhanced Transponder System

- 10.4.1. Not Applicable

### 10.5. Leader Light System

- 10.5.1. Not Applicable

### 10.6. Back-lit Panel

- 10.6.1. Not Applicable

### 10.7. Pro-Am Light

- 10.7.1. Not Applicable

### 10.8. In-Car Camera

- 10.8.1. Not Applicable

## ARTICLE 11. REFUELING SYSTEM

### 11.1. Fuel Transfer

- 11.1.1. Not Applicable

### 11.2. Pit Tank

- 11.2.1. Not Applicable

### 11.3. Peripheral Connections

11.3.1. Not Applicable

**11.4. Refueling Hose**

11.4.1. Not Applicable

**11.5. Trolley**

11.5.1. Not Applicable

**11.6. Boom**

11.6.1. Not Applicable

**11.7. Refueling Restrictor**

11.7.1. Not Applicable

**11.8. Level Sensor System**

11.8.1. Not Applicable