

2019 TECHNICAL REGULATIONS

Revision Date: 02 January 2019



Series:

IMSA MICHELIN PILOT CHALLENGE



Class:

TCR



Sanctioned by:

**INTERNATIONAL
MOTOR SPORTS
ASSOCIATION**

One Daytona Blvd.
Daytona Beach, FL 32114
(O) +1 (386) 310-6500
(F) +1 (386) 310-6695
www.imsa.com

Table of Contents

ARTICLE 1. DEFINITIONS SPECIFIC TO THE TECHNICAL REGULATIONS	5	9.1. General	14
ARTICLE 2. TECHNICAL PHILOSOPHY	6	9.2. Modifications to the Specification	14
2.1. Technical Eligibility	6	9.3. Servicing, Repair, and Replacement	14
2.2. Balance of Performance Adjustment	6	9.4. Dimensions	14
2.3. Changes	6	9.5. Chassis	15
ARTICLE 3. USING THESE TECHNICAL REGULATIONS	6	9.6. Driver Interface	15
3.1. Structure	6	9.7. Bodywork	16
3.2. Conflict Resolution	7	9.8. Aerodynamic Elements	16
3.3. Final Authority	7	9.9. Engine System	16
ARTICLE 4. HOMOLOGATION	7	9.10. Boost Management	17
4.1. Homologation Regulations	7	9.11. Drive System	17
4.2. Homologation Process	7	9.12. Cooling System	18
4.3. Homologation Files and Documentation	7	9.13. Fuel System	18
4.4. Homologation Inspection	8	9.14. Brake System	18
4.5. Homologation Testing	8	9.15. Steering System	19
4.6. Homologation Identifier	8	9.16. Suspension System	19
4.7. Conditions for Use of a Specific Homologation	8	9.17. Wheels & Tires	19
ARTICLE 5. TECHNICAL ELIGIBILITY	9	9.18. Electronics	19
5.1. Technical Credential Process	9	ARTICLE 10. SERIES REQUIRED ELECTRONICS	21
5.2. Technical Credential Files and Documentation	9	10.1. Series Scrutineering Data System	21
5.3. Technical Eligibility Testing	9	10.2. Safety Light System	22
5.4. Technical Credential Identifier	10	10.3. Driver ID System	22
5.5. Conditions for Use of Specific Technical Credential	10	10.4. X2 Transponder System	23
ARTICLE 6. CLASS STRATIFICATION MEASURES	10	10.5. Leader Light System	23
6.1. General Stratification	10	10.6. Back-lit Panel	23
6.2. Criteria for Adjustments	10	10.7. Pro-Am Light	23
6.3. Adjustment Parameters	10	10.8. In-Car Camera	23
6.4. Balance of Performance	10	ARTICLE 11. REFUELING SYSTEM	24
ARTICLE 7. SAFETY	10	11.1. Fuel Transfer	24
7.1. Driver Safety Harness System	10	11.2. Pit Tank	24
7.2. Seat	11	11.3. Peripheral Connections	24
7.3. Driver Containment Nets	11	11.4. Refueling Hose	25
7.4. Protective Padding	12	11.5. Tank Support Stand	26
7.5. Protective Shielding	12	11.6. Boom	26
7.6. Master Electrical Switches	12	11.7. Refueling Restrictor	26
7.7. Fire Suppression System	12	11.8. Level Sensor System	27
ARTICLE 8. DEFINITION OF CLASS	13		
8.1. TCR	13		
ARTICLE 9. VEHICLE SYSTEMS	14		

Foreword:

For all Members, the IMSA RULES of the International Motor Sports Association establish the foundation for the organization and conduct of all IMSA Sanctioned Events. The IMSA RULES take effect immediately upon publication.

The purpose of the RULES is to: (i) promote safety, the sport of automobile Competition and IMSA, (ii) enhance Competition, (iii) ensure the quality, fairness and integrity of the IMSA programs and operations and (iv) achieve prompt finality in the Competition results (“Purpose”).

ALL MEMBERS ARE REQUIRED TO REVIEW THESE IMSA RULES CAREFULLY.

The IMSA RULES consist of following three (3) sections and the Event Supplementary Regulations (SR):

- The Technical Regulations, which outline the rules and regulations for the specific cars and equipment. The Technical Regulations may be modified or changed at any time by the publication of a Technical Bulletin, amending the Technical Regulations.
- The IMSA Sporting Regulations (ISR), which concern Competitor and Event procedures, as well as guidelines for the safe and uniform operation of the sport. The ISR may be modified or changed at any time by the publication of a Competition Bulletin, amending the ISR.
- The Series Supplementary Regulations (SSR) that provides Series-specific information about each IMSA Series. The SSR is integrated into the ISR and are designated with “(SSR)” next to the Paragraph title. The SSR may be modified or changed at any time by the publication of a Competition Bulletin, amending the SSR.

Any portion of the RULES may be modified though Bulletins (Competition Bulletins and Technical Bulletins, respectively) and takes force when published. Once published, the Bulletin shall take precedence over the applicable portion of the RULES. Additionally, the RULES may be modified for an Event by the Race Director through the mandatory briefing instructions.

HOW TO READ THE RULES

These Technical Regulations are a Permissive document. Unless specifically defined as permitted, any modification, change, or adjustment is inherently prohibited. This philosophy is more clearly defined in Article 4 and specific modifications are clearly defined in Article 9.

The Technical Regulations are specific to particular categories, classes and types of race cars in a Series. Where the Technical Regulations conflict with the ISR or the SSR, the Technical Regulations shall govern.

The SR is specific to an Event and published in conjunction with the Event schedule. Where SR conflicts with the ISR, SSR, and/or Technical Regulations, the SR shall govern.

EXECUTIVE LEADERSHIP MASTHEAD

John Bishop* / Bill France, Sr.*

Founders – IMSA

Dr. Don Panoz*

Legacy Vice Chairman

Jim France

Chairman

Lesa Kennedy

Director

Ed Bennett

Chief Executive Officer

Scott Atherton

President

Karen Leetzow

Director and Legal Counsel

Simon Hodgson

Vice President, Competition

David Pettit

Vice President, Marketing

***Deceased**

ARTICLE 1. DEFINITIONS SPECIFIC TO THE TECHNICAL REGULATIONS

- 1.1.1. **Car** means a singular representation of a Car Model possessing a Technical Credential, entered by an Entrant in an Event.
- 1.1.2. **Car Model** means a specific model of a vehicle constructed by an IMSA-recognized Manufacturer Partner, and intended for Competition.
- 1.1.3. **Class** means a category for Cars sharing a common set of Homologation Regulations and differentiated from others by type of Car Model.
- 1.1.4. **Competition** means a contest of competitive nature in which a Car takes part during an Event and results of which Competition are published.
- 1.1.5. **Constructor** means an entity that designs and builds race car chassis.
- 1.1.6. **Entrant** means an entity or person who has entered a Car that has been accepted for Competition and holds an IMSA Membership in the capacity of an Entrant or Entrant/Driver.
- 1.1.7. **Event** means an IMSA Sanctioned motorsport activity. It includes the designated Race as well as all periods for registration, inspections, practice Sessions, qualifying Sessions, racing, pre- and post-Race activities and inspections, and rain or postponed dates related thereto.
- 1.1.8. **Homologate** means to execute the Homologation Process.
- 1.1.9. **Homologated** means a Car Model approved through the Homologation Process.
- 1.1.10. **Homologation** means the concept of all things associated with Homologation Authority approval via the Homologation Process.
- 1.1.11. **Homologation Authority** means an entity with the authority to Homologate.
- 1.1.12. **Homologation Documentation** means all files, documents, information, and communication associated with the issuance of official approval of Homologation.
- 1.1.13. **Homologation Identifier** means the unique identifier (generally including a string of characters identifying the Category or Class of Homologation followed by a sequential number assigned to the Car Model) serving as a reference to the official approval of Homologation, assigned by the Homologation Authority.
- 1.1.14. **Homologation Process** means all procedures associated with petitioning a Homologation Authority for approval that a Car Model complies with the Homologation Regulations.
- 1.1.15. **Homologation Regulations** means a set of technical requirements and criteria used to design, construct, and document a Car Model intended for racing in a specific category or class of racing.
- 1.1.16. **Manufacturer** means a Manufacturer Partner constructing an approved Car Model.
- 1.1.17. **Manufacturer Partner** means a recognized IMSA Official Automotive Partner.
- 1.1.18. **Permissive** means modifications explicitly authorized by these Technical Regulations are permitted and modifications not explicitly authorized by these Technical Regulations are prohibited.
- 1.1.19. **Specification** means all technical characteristics of the Car Model defined by the Homologation and Technical Credential.
- 1.1.20. **Specific Homologation** means the Homologation specific to a particular Car Model.
- 1.1.21. **Specific Technical Credential** means the Technical Credential specific to a particular Car Model.
- 1.1.22. **Technical Credential** means the concept of all things associated with IMSA approval via the Technical Credential Process.
- 1.1.23. **Technical Credential Documentation** means all files, documents, information, and communication associated with the Technical Credential Process.
- 1.1.24. **Technical Credential Identifier** means the unique identifier that serves as a reference to the Technical Credential granted by the IMSA. Example: IMSA GTLM 20170101 [GTE-0XX].
- 1.1.25. **Technical Credential Process** means all procedures associated with petitioning IMSA for approval that a Car Model is Technically Eligible.

- 1.1.26. **Technical Eligibility Form** means the form which documents the Specific Technical Credential.
- 1.1.27. **Technically Eligible** means conforms to all technical requirements and criteria defined by these Technical Regulations.

ARTICLE 2. TECHNICAL PHILOSOPHY

2.1. Technical Eligibility

- 2.1.1. Car Models Technically Eligible for participation in IMSA Events are issued a Technical Credential Identifier.
- 2.1.2. Cars representing a Car Model must always respect the Specification.
- 2.1.3. To be issued a Technical Credential Identifier for participation in this Class, a Car Model must:
 - a. Be a Car Model constructed by an IMSA-recognized Manufacturer Partner.
 - b. Hold a valid Homologation conforming to the Homologation Regulations and Homologation Documentation specific to the Class, approved and issued by an IMSA-recognized Homologation Authority.
 - c. Successfully complete the IMSA Technical Credential Process.
- 2.1.4. IMSA is the sole authority to define the Technical Eligibility of a Car Model and issue the Technical Credential.

2.2. Balance of Performance Adjustment

- 2.2.1. To maintain competitive equivalency between Cars within the Class, and between Classes, IMSA uses the Balance of Performance process to mandate adjustments to the Specification.

2.3. Changes

- 2.3.1. Changes to the Specification are prohibited, unless explicitly authorized by IMSA.
- 2.3.2. Manufacturers alone must petition IMSA to change the Specification; requests by Entrants are not recognized.

ARTICLE 3. USING THESE TECHNICAL REGULATIONS

3.1. Structure

- 3.1.1. These Technical Regulations are structured to assist Manufacturers and Entrants in accurate interpretation of the technical expectations and enforcement of the IMSA Technical Philosophy.
 - a. A brief description of each Article and its purpose follows:

Article / Name	Description / Purpose
1. Definitions Specific to the Technical Regulations	Standardized meanings for specific terms of these Technical Regulations.
2. Technical Philosophy	Guiding principles for these Technical Regulations.
3. Using These Technical Regulations	General structure, purpose, and clarifying statements for these Technical Regulations.
4. Homologation	Pertinent topics related to Homologation.
5. Technical Eligibility	Pertinent topics related to Technical Eligibility.
6. Balance of Performance	General processes associated with competitive equivalency.
7. Safety	Regulatory requirements associated with mandatory safety systems.
8. Definition of Class	Statement of specific Class, Homologation, and Technical Eligibility requirements.
9. Series Required Electronics	Regulatory requirements associated with mandatory electronic systems.
10. Vehicle Systems	Approved modifications to the Homologation component of the Car Model Specification.
11. Refueling System	Regulatory requirements associated with specified refueling system.

3.2. Conflict Resolution

- 3.2.1. These IMSA Technical Regulations shall govern in any case where a conflict exists with the Homologation Regulations and Documentation.

3.3. Final Authority

- 3.3.1. IMSA is the Final Authority with respect to these Technical Regulations.

ARTICLE 4. HOMOLOGATION

4.1. Homologation Regulations

- 4.1.1. Reference to the official Homologation Regulations defining the requirements applicable to these Technical Regulations is provided in ARTICLE 8. DEFINITION OF CLASS.

4.2. Homologation Process

- 4.2.1. The procedures of the Homologation Process are used to verify that the Car Model meets the necessary requirements and criteria defined by the official set of Homologation Regulations.
- 4.2.2. This process generally includes the following components or phases, which must be completed to the satisfaction of the Homologation Authority:
- a. Homologation Files and Documentation
 - b. Homologation Inspection
 - c. Homologation Testing
 - d. Final Approval
 - e. Identification Assignment
- 4.2.3. Homologation Process fees may apply.

4.3. Homologation Files and Documentation

- 4.3.1. All files and documents required by the Homologation Authority to support the Homologation Process; including but not limited to:
- a. Basic Homologation Form
 - b. Homologation Extension Form(s)
 - c. Data Sheet(s)
 - d. CAD Models and Drawings
 - e. Logged Vehicle Data
 - f. Homologation Testing Data
- 4.3.2. Basic Homologation Form: Documents how the Car Model complies with the Homologation Regulations; including photographs, drawings, descriptions, and measurements defining the characteristics, components, parameters, and/or dimensions and tolerances for:
- a. General Vehicle
 - b. Specific Vehicle Systems
 - c. System Assemblies, Parts and Components
 - d. Modifications to the Original Series Production Car (if applicable)
- 4.3.3. Homologation Extension Forms: Describe all approved modifications made to the Basic Homologation Form, including but not limited to modifications for:
- a. Correction of incorrect information
 - b. Safety reasons
 - c. Reliability reasons
 - d. Evolutions of type introduced on the original Car Model (if applicable)
 - e. Evolutions for new components and/or characteristics that cancel and replace those featured in the original Basic Homologation Form
 - f. Variant options, such as endurance packages

- 4.3.4. CAD Models and Drawings: As required by the Homologation Authority to support the Homologation Process; including but not limited to:
 - a. Complete Vehicle CAD Models
 - b. Specific Component CAD Models
 - c. Specific Component Drawings
 - d. Engine Air Intake Restrictor(s)
- 4.3.5. Homologation Testing Data: Information, documentation, data, and results from Homologation Testing.

4.4. Homologation Inspection

- 4.4.1. The inspection process for drawings, CAD models, any reference component, and the constructed Car Model by the Homologation Authority.
 - a. These inspections confirm that a Car Model complies with the Homologation Regulations and are generally conducted as part of the following phases of the Homologation Process:
 - i. Design
 - ii. Construction
 - iii. Final Approval

4.5. Homologation Testing

- 4.5.1. Any testing conducted by the Homologation Authority to support the Homologation Process; including, but not limited to:
 - a. Straight-line Testing
 - b. Wind Tunnel Testing
 - c. Engine Dyno Testing
 - d. Track Testing

4.6. Homologation Identifier

- 4.6.1. The Homologation Identifier is electronically stamped/associated with all information, documentation and files associated with the Homologation.

4.7. Conditions for Use of a Specific Homologation

- 4.7.1. At all times during IMSA-sanctioned Events it is the Entrant's responsibility to ensure the configuration of the Car Model represents the Homologation components of the Specification; including:
 - a. As-Homologated Configuration
 - b. As-Delivered Configuration
 - c. Parts Manual
 - d. Homologation Extension Form Configuration
- 4.7.2. The original, As-Homologated Configuration of the Car Model must not be modified unless permitted by these Technical Regulations.
- 4.7.3. The As-Delivered Configuration of a Car must respect the as-received configuration from the Car Model Manufacturer, unless permitted by these Technical Regulations.
- 4.7.4. The Parts Manual is the official parts catalogue for the Car Model as defined by the Car Model Manufacturer or Constructor:
 - a. Specific parts listed in the Parts Manual must be used on all representations of a Car Model unless permitted by these Technical Regulations.
- 4.7.5. To be eligible for use in any IMSA-sanctioned Event, modifications detailed in Homologation Extension Forms must:
 - a. Comply with these Technical Regulations.
 - b. Be approved by, or have initiated the process to obtain approval from, the Homologation Authority, and appended to the Car Model Homologation.
 - c. Be approved by IMSA.
 - d. Be available to all Entrants of the relevant Homologated Car for the next Event.

ARTICLE 5. TECHNICAL ELIGIBILITY

5.1. Technical Credential Process

- 5.1.1. Manufacturers may begin the Technical Credential Process for a Car Model provided the Car Model:
 - a. Holds, or have initiated the process to obtain approval from, a valid Homologation as defined in these Technical Regulations.
 - b. Is approved by IMSA.
- 5.1.2. The procedures of the Technical Credential Process are used to verify that the Car Model meets the necessary requirements and criteria defined by these Technical Regulations.
- 5.1.3. This process generally includes the following components or phases, which must be completed to the satisfaction of IMSA:
 - a. Technical Credential Files and Documentation
 - b. Technical Eligibility Testing
 - c. Final Approval
 - d. Identification Assignment
- 5.1.4. IMSA may request Manufacturers submit reference components to support the Technical Credential process.
 - a. IMSA may retain these components without compensation.
- 5.1.5. IMSA may request Manufacturers submit reference tooling and/or templates to support the Technical Inspection process.
- 5.1.6. Technical Credential fees may apply.

5.2. Technical Credential Files and Documentation

- 5.2.1. All files and documents required by IMSA to support the Technical Credential Process; including but not limited to:
 - a. Technical Eligibility Form
 - b. Data Sheet(s)
 - c. CAD Models and Drawings
 - d. Logged Vehicle Data
 - e. Electronic Controller Calibrations
 - f. Technical Eligibility Testing Data
- 5.2.2. Technical Eligibility Form: Documents how the Car Model complies these Technical Regulations; including:
 - a. List of all files and documentation associated with the Specific Homologation of the Car Model
 - b. List of all files and documentation associated with the Specific Technical Credential of the Car Model
 - c. All approved IMSA-Only Declarations
- 5.2.3. CAD Models and Drawings: As required by IMSA to support the Technical Credential Process; including but not limited to:
 - a. Complete Vehicle CAD Models
 - b. Specific Component CAD Models
 - c. Specific Component Drawings
 - d. Additional components requested by IMSA
- 5.2.4. Technical Eligibility Testing Data: Information, documentation, data, and results from Technical Eligibility Testing.

5.3. Technical Eligibility Testing

- 5.3.1. Any testing conducted by IMSA to support the Technical Credential Process; including, but not limited to:
 - a. Restrictor Flow
 - b. Engine Dyno
 - c. Wind Tunnel
 - d. On-track Testing
 - e. Refueling Testing

5.4. Technical Credential Identifier

- 5.4.1. The Technical Credential Identifier is electronically stamped/associated with all information, documentation and files associated with the Technical Credential.

5.5. Conditions for Use of Specific Technical Credential

- 5.5.1. At all times during IMSA-sanctioned Events it is the Entrant's responsibility to ensure the configuration of the Car Model represents the approved Technical Credential components of the Specification.

ARTICLE 6. CLASS STRATIFICATION MEASURES

6.1. General Stratification

- 6.1.1. IMSA shall determine variation from the TCR International BoP specifications to insure the following for TCR
- To preserve competition with the TCR class with minimal interference from out-of-class Cars
 - To preserve competition in other Classes with minimal interference from TCR Cars

6.2. Criteria for Adjustments

- 6.2.1. IMSA shall determine, together with WSC International, observed performance indicative of the TCR class including the following areas;
- Vehicle Data
 - Timing/Scoring Data
 - Technical Documentation

6.3. Adjustment Parameters

- 6.3.1. IMSA Shall determine:
- The overall TCR class power levels
 - Mass variance from the TCR International BoP

6.4. Balance of Performance

- 6.4.1. IMSA Shall determine:
- Fuel Capacity
 - Refueling Restrictor

ARTICLE 7. SAFETY

7.1. Driver Safety Harness System

- 7.1.1. Cars must be equipped with a minimum 6-point Driver safety harness with a valid label demonstrating compliance with one of the following standards:
- FIA Standard 8853/98: FIA Safety Harnesses Standard
 - [FIA Technical List #24](#): Harnesses Homologated by the FIA according to the FIA Standards 8853/98 and 8854/98
 - FIA Standard 8853-2016: Safety Harnesses
 - [FIA Technical List #57](#): Harnesses Homologated according to the FIA Standard 8853-2016
 - SFI Specification 16.5: Stock Car Driver Restraint Assemblies
 - [Specification](#)
 - [Manufacturers](#)
 - SFI Specification 16.6: Advanced Motorsport Driver Restraint Assemblies
 - [Specification](#)
 - [Manufacturers](#)

- 7.1.2. Installation must be performed in accordance with instructions provided by the system supplier and/or manufacturer.
- Belt components must be installed at each anchor point to prevent accidental release or opening.
 - Individual belt straps must be independent; any method or attempt to combine individual straps is prohibited.
 - Elastic retention straps are prohibited on shoulder belts
- 7.1.3. Harnesses must be replaced at the request of IMSA, or whenever the following conditions occur:
- Expiration:
 - FIA Homologated: Immediately following December 31st of the year printed on the label.
 - SFI Certified (punched/cut label): Two years from the date as stated on label. If label is not properly “cut” by the manufacturer or their representative, the date for expiration shall be January 1st of the earliest year printed on the label + two years
 - SFI Certified (non-punched label): On June 30th or December 31st: of the year identified as the date for expiration
 - Damage:
 - Following a severe collision.
 - Webbing is cut or frayed, or weakened due to actions of chemicals or sunlight.
 - Buckles are bent, deformed, rusted, or improperly functioning.
- 7.1.4. Entrants are responsible for ensuring the Driver safety harnesses and all associated components are properly labeled, installed, used, and maintained.
- 7.1.5. Belt components must be used as designed by the manufacturer and tested by SFI or FIA. It is prohibited to “mix” belt components to include:
- Belt components from different manufacturers.
 - Belt components certified by SFI and FIA.

7.2. Seat

- 7.2.1. As Homologated

7.3. Driver Containment Nets

- 7.3.1. Cars must be equipped with center, and Driver-side containment nets with a valid label demonstrating compliance with one of the following:
- FIA Standard 8863-2013: Racing Nets
 - [FIA Technical List #48](#): Racing Nets Homologated according to the FIA Standard 8863-2013
 - SFI Specification 37.1: Roll Cage Nets
 - [Specification](#)
 - [Manufacturers](#)
- 7.3.2. Installation requirements:
- Supplier and/or manufacturer installation instructions must be respected.
 - Horizontal webbing must be oriented towards the Driver.
 - When secured at anchor points, nets must be:
 - Oriented parallel to the Car centerline.
 - Located with minimal gap to the Driver’s helmet.
 - Signage or equipment may be attached to nets provided:
 - The designed purpose of the net is respected.
 - Visibility over and/or through the net is unobstructed.
- 7.3.3. Containment nets must be replaced prior to the expiration date:
- FIA Homologated: Immediately following December 31st of the year printed on the label.

- b. SFI Certified: (punched/cut label): Two years from the date as stated on label. If label is not properly “cut” by the manufacturer or their representative, the date for expiration shall be January 1st of the earliest year printed on the label + two year.
- c. SFI Certified (non-punched label): On June 30th or December 31st: of the year identified as the date for expiration.

7.4. Protective Padding

- 7.4.1. Cars must be equipped with non-flammable protective padding with a valid label demonstrating compliance with one of the following standards:
 - a. FIA Standard 8857-2001: FIA Roll Cage Padding Standard
 - i. [FIA Technical List #23](#): Roll Cage Padding Homologated by the FIA
 - b. SFI Specification 45.1: Roll Cage Padding
 - i. [Specification](#)
 - ii. [Manufacturers](#)
- 7.4.2. Installation requirements:
 - a. Padding must be located to protect the Driver (body and/or helmet) against direct contact with the safety cage in a collision.
 - b. Protective padding must be securely affixed to prevent rolling or displacement.

7.5. Protective Shielding

- 7.5.1. Cars may be equipped with shielding to protect the Driver against contact with cockpit equipment in a collision.
- 7.5.2. Installation requirements:
 - a. Installations must not impact cockpit exit.
 - b. Installations of protective shielding must use fire-resistant materials and if impact padding is used it must comply with FIA 8857-2001, SFI 45.1 or SFI 45.2.
 - c. Installations must be ~~approved by~~ presented to and approved by IMSA at the time of technical inspection.

7.6. Master Electrical Switches

- 7.6.1. As homologated
- 7.6.2. Systems must remain functional during any on-track activity or at the request of IMSA.
- 7.6.3. Interior and exterior master switches must be clearly identified by a self-reflective symbol of a red spark surrounded by a white-edged, blue triangle with a base greater than 30 mm.

7.7. Fire Suppression System

- 7.7.1. Cars must be equipped with a fire extinguisher system with a valid label demonstrating compliance with one of the following standards:
 - a. FIA Standard for plumbed-in Fire Extinguisher Systems in Competition Cars (1999):
 - i. [FIA Technical List #16](#): Extinguisher Systems Homologated by the FIA
 - b. FIA Standard 8865-2015: Plumbed-in and Hand-Held Fire Extinguisher Systems
 - i. [FIA Technical List #52](#): Plumbed-in Fire Extinguisher Systems according to FIA Standard 8865-2015
 - c. SFI Specification 17.1: On Board Fire Suppression Systems
 - i. [Specification](#)
 - ii. [Manufacturers](#)
- 7.7.2. Extinguishing media must be compatible with all aspects and accessories of the fire suppression system.
 - a. Compliance with FIA 8865-2016 is recommended.
 - b. All system components must be used and serviced per manufacturer specifications.

- 7.7.3. System must be securely mounted.
- a. The following must be visible without the use of photography, tools, or seat removal:
 - i. Pressure gauge (if present)
 - ii. Date of manufacture
 - iii. Next required service date
 - b. Nozzles must not point directly at the Driver's face.
- 7.7.4. System must include an exterior activation mechanism proximal to the exterior master electrical switch at (or near) the base of the right side A-Pillar.
- a. Exterior activation mechanism must be located such that emergency responders may activate with a single action:
 - i. Using a gloved finger, or tools such as a hook.
 - ii. Unencumbered by bodywork, windscreen wipers, or any equipment that may require multiple actions.
 - b. A method for preventing activation of the exterior activation mechanism:
 - i. May be enabled when the Car is in Technical Inspection, in the Paddock, or located near large crowds, such as during pre-Race activities.
 - ii. Must be removed prior to participation in on-track activity.
- 7.7.5. Identification
- a. Exterior activation mechanism must be marked with a self-reflective symbol with a red edge surrounding a red "E" inside a white circle at least 100 mm in diameter.
- 7.7.6. Inspection
- a. IMSA may require removal of the fire bottle for Technical Inspection.
 - b. Entrant is responsible to demonstrate proper system function of the interior and exterior fire suppression activation mechanisms, using the "test" mode if present.

ARTICLE 8. DEFINITION OF CLASS

8.1. TCR

- 8.1.1. Class Structure: TCR cars compete in the TCR Class of the IMSA Michelin Pilot Challenge (IMPC).
- 8.1.2. Eligibility Requirements: To be eligible for participation in the Class, a Car Model must respect the Specification defined by the Homologation and Technical Eligibility requirements:
- a. Homologation (TCR):

Homologation Authority:	World Sporting Authority LTD (WSC)
Homologation Specification:	World Sporting Authority LTD (WSC) Group TCR
Homologation Regulations:	WSC Group TCR Homologation Regulations
Additional Documentation:	WSC Group TCR Technical Regulations

ARTICLE 9. VEHICLE SYSTEMS

9.1. General

- 9.1.1. All Vehicle Systems and associated sub-systems are listed in this Article.
- Where change to these Vehicle Systems is permitted, regulatory text is **bold and underlined**.
 - Where change to these Vehicle Systems is prohibited, regulatory text is light grey.
 - Advisory statements are in normal text.

9.2. Modifications to the Specification

- 9.2.1. Entrants may execute the following changes to parameters defined by the Homologation component of the Car Model Specification, provided these Technical Regulations, all current Technical Bulletins, and the Technical Credential are fully respected:
- Adjust component settings defined as adjustable.
 - Replace components with parts defined as optional.
- 9.2.2. Manufacturers must make any declarations listed in these Technical Regulations in the Technical Eligibility Form.
- 9.2.3. Further authorization to modify the Specification and/or As-Delivered Condition is granted via the following formal communication methods:
- Published IMSA Technical Bulletin
 - Approved updates to the IMSA Technical Eligibility Form
- 9.2.4. Informal and/or verbal communication is not considered valid authorization.

9.3. Servicing, Repair, and Replacement

- 9.3.1. All servicing or repair must be made in good faith to restore the Car and all components to their originally intended form and function as defined by the Specification.
- 9.3.2. Entrants may replace damaged or worn components provided these Technical Regulations are respected.

9.4. Dimensions

- 9.4.1. General
- IMSA's measurement instruments are the official measurement instruments.
- 9.4.2. Reference Surface
- The lowest plane of the underside of the car of the Car is measured to the Technical Inspection scale plane.
- 9.4.3. Mass
- The minimum mass for all Car Models is defined via Balance of Performance Tables and associated Technical Bulletins.
 - Car mass is measured as-raced minus Driver and Fuel using the IMSA scales during Technical Inspection.
- 9.4.4. Ballast
- Entrants may add or remove ballast to achieve minimum mass:**
 - Ballast must be in plate or panel form.
 - Addition or removal of ballast during the race is prohibited.
 - Entrants using Cars without specific Homologated locations must:**
 - Locate all ballast inside the cockpit in the passenger's location.
 - Secure all ballast per FIA Article 253-16 in both dimensions and characteristics of fixation methods.
 - Design fixations such that tools are required for its removal.

9.4.5. Minimum Ride Height

- a. The minimum ride height for all Car Models is defined via Balance of Performance Tables and associated Technical Bulletins.
- b. Ride Height is measured at the points specified in the Homologation Document during Technical Inspection.

9.4.6. Overall Dimensions

- a. Length
- b. Width
- c. Height
- d. Wheelbase
- e. Track
- f. Overhang
- g. Width

9.5. Chassis

9.5.1. General

- a. **Entrants may execute minimum modifications for the installation of components.**
 - i. All modifications must be approved by IMSA.

9.5.2. Air Jack System

- a. Air Wand Receptacle
 - i. Air wand receptacles may be repositioned symmetrically about the longitudinal axis of the car unless alternate mounting locations are specifically identified in the Homologation Document.

9.6. Driver Interface

9.6.1. General

9.6.2. Steering Wheel

9.6.3. Pedal Box

- a. **Entrants may apply non-slip adhesives to the surface of driver pedals.**

9.6.4. Shifting Mechanism

9.6.5. Driver Adjustable Components

9.6.6. Driver Cooling Systems

- a. **Entrants may install a maximum of two (2) Driver Cooling Systems, i.e. Cool Suits.**
 - i. Evaporative-loss Freon cool suits are prohibited.
- b. Installations must be approved by IMSA and meet the following conditions:
 - i. The mounting location and installation for the primary system is unrestricted provided it serves no purpose other than retaining the cooling system in the event of a collision.
 - ii. Any secondary driver cooling system must be mounted on the top of the ballast box.
 - iii. All driver cooling system containers must be securely mounted.
 - iv. The use of hook and loop fasteners (Velcro) is prohibited.

- c. Entrants may install Driver Ventilation Ducts
 - i. A NACA duct may be installed on the side window, rear quarter window, OR the rear window for the purpose of cooling the driver
 - ii. Maximum of 1 per side with 2 ducts permitted per car
 - iii. Maximum cutout area of 26 cm x 16 cm
 - iv. No duct shall break the outward plane of the surface on which it is installed
 - v. Ducts must be translucent
 - vi. Duct and/or hoses must not impede cockpit exit or driver's visibility
 - vii. All installations must be approved by IMSA in writing and added to the Technical eligibility credential on file

9.7. Bodywork

9.7.1. General

a. Entrants may install the following films to the front windscreen:

- i. Tear-off
- ii. Anti-fog

9.7.2. Bodywork Seams

a. Entrants may apply tape over the body seams around refueling receptacles.

9.7.3. Decals

a. Entrants may apply removable die cut sponsorship decals with the approval of IMSA.

9.8. Aerodynamic Elements

9.8.1. General

- a. Manufacturer seals must be respected

9.8.2. Splitter

9.8.3. Dive Planes

9.8.4. Body Gurney

9.8.5. Wings

9.8.6. Rear Wing Gurney

9.8.7. Floor

9.8.8. Friction Blocks

9.8.9. Diffuser

9.9. Engine System

9.9.1. General

9.9.2. Engine

9.9.3. Lambda

9.9.4. Engine RPM

9.9.5. Intake

9.9.6. Exhaust

9.9.7. Turbo

9.9.8. Engine Control Unit (ECU)

9.9.9. Engine Transportation Crate

- a. Entrant must have immediately available a crate sufficient to securely and safely package and ship an engine.

9.10. Boost Management

- 9.10.1. Maximum Boost Pressure
- 9.10.2. Boost Pressure Ratio
- 9.10.3. Boost Control Strategy Inputs
 - a. All parameters as measured by the Series Scrutineering Logger
 - i. Boost Pressure
 - ii. RPM
 - iii. Throttle Position
 - iv. Gearshift
- 9.10.4. Calculation Method
 - a. Conditions for calculation window
 - i. Engine speed above 2000rpm
 - ii. Throttle pedal position greater than 25%
 - iii. No gearshift within 200rpm or 1000ms
 - iv. No gear upshift detected per the following formula reaching 200:
 - a. $\text{drop}(t) = \text{rpm}(t-20) - \text{rpm}(t)$
 - b. t is defined in ms
 - v. Sampling resolution of 1 mbar
 - vi. Sampling rate of 100 Hz
 - b. Monitoring Method
 - i. Rolling average of 50 samples
 - ii. $\text{OB} = P_{\text{rolling average}} - P_{\text{limit}}$
 - iii. If OB is greater than zero, the result is forwarded
 - iv. High OB threshold (100mbar) cannot be exceeded
 - v. Low OB threshold (30mbar) cannot be exceeded more than 5 times in a stint

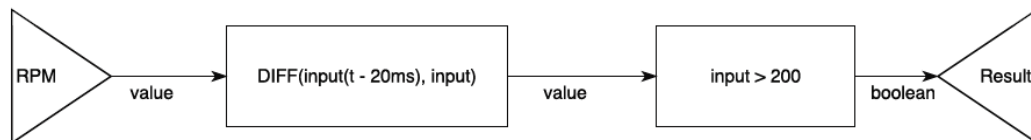

9.11. Drive System

- 9.11.1. General
 - a. Manufacturer seals must be respected
- 9.11.2. Fluids & Lubricants
 - a. **Unrestricted.**
- 9.11.3. Clutch
- 9.11.4. Gearbox
- 9.11.5. Gears
- 9.11.6. Gearbox Control Unit
- 9.11.7. Differential
- 9.11.8. Axles
- 9.11.9. Uprights

9.12. Cooling System

- 9.12.1. General
- 9.12.2. Fluids
 - a. **Entrants may utilize non-glycol based fluids.**
- 9.12.3. Inlet Blockers
- 9.12.4. Water System
- 9.12.5. Oil Cooling System

9.13. Fuel System

- 9.13.1. General
 - a. Maximum Capacity
 - i. The maximum fuel capacity for all Car Models is defined via Balance of Performance Tables and associated Technical Bulletins.
 - ii. The maximum fuel capacity is the total volume of fuel contained in the Car.
- 9.13.2. Fuel Types
 - a. The approved fuel for the Class is IMSA E10, as supplied by VP Fuels.
 - i. IMSA may require a fuel sample for inspection via a gas chromatograph.
- 9.13.3. Fuel Cell
 - a. **Entrants may use blocks or balls to achieve maximum fuel cell capacity:**
 - i. Any device, system, or procedure designed to increase, even temporarily, the total fuel storage capacity beyond the maximum is prohibited.
- 9.13.4. Fuel Lines
- 9.13.5. Fuel Sample Port
 - a. **Entrants must equip the Car with the approved self-sealing connector for extraction of fuel samples:**
 - i. Approved Connector: Staubli P/N: CBI06.7251/IA/JKV.
 - ii. Must be located immediately before the injector nozzles.
 - iii. Installation must be approved by IMSA.
- 9.13.6. Refueling Receptacle

9.14. Brake System

- 9.14.1. General
- 9.14.2. Fluids & Lubricants
 - a. **Unrestricted.**
- 9.14.3. Bias Assembly
- 9.14.4. Master Cylinders
- 9.14.5. Brake Lines
- 9.14.6. Calipers
- 9.14.7. Rotors
- 9.14.8. Pads
 - a. **Friction material is unrestricted.**
 - b. Backing Plates must be ferrous.
- 9.14.9. Ducting

9.14.10. Brake Duct Inlet Blockers

- a. **Entrants may apply opaque adhesive tape to block off portions of the brake duct inlet openings.**

9.14.11. Anti-Lock Braking System

9.15. Steering System

9.15.1. General

9.15.2. Fluids & Lubricants

- a. **Unrestricted.**

9.16. Suspension System

9.16.1. General

9.16.2. Geometry Elements

9.16.3. Springs

- a. **Spring rates are unrestricted**

9.16.4. Dampers

- a. **Valving may be changed**
- b. Inerters may not be used

9.16.5. Bump Rubbers and Packers

- a. **Unrestricted.**

9.16.6. Anti-Roll Bar

9.16.7. Third Elements

9.17. Wheels & Tires

9.17.1. General

9.17.2. Wheels

9.17.3. Wheel Attachment

9.17.4. Tires

- a. The approved tire supplier for this Class is Michelin.

9.18. Electronics

9.18.1. General

9.18.2. Data Logger

- a. **Entrants may install a data acquisition system where not available in the As-delivered Car.**
- b. IMSA reserves the right to download and/or view all logged data at any time.

9.18.3. Telemetry

- a. Telemetry is prohibited.

9.18.4. Wiring Loom

- a. All data acquisition equipment must use a separate visible and traceable wiring loom.

9.18.5. Sensors

a. **Entrants may install the following approved sensors/inputs:**

- i. One longitudinal and one lateral G load sensor
- ii. Front and/or rear brake pressures
- iii. Wheel speed sensors (maximum 4)
- iv. Steering input
- v. Throttle position
- vi. Water Temperature
- vii. Oil Pressure
- viii. Oil Temperature
- ix. Gearbox Temperature
- x. Differential (or Rear End) Temperature
- xi. Fuel Pressure
- xii. GPS
- xiii. CAN Interface
- xiv. Manifold Pressure / Vacuum (Mandatory on cars with Forced Induction)

9.18.6. Radio

a. **Entrants may install a single two-way voice radio with car-to-pit communication capability in compliance with the corresponding Series Sporting Regulations.**

9.18.7. Rear View Camera

a. **Where not homologated, Entrants may install a rear-view camera system.**

9.18.8. Auxiliary Power Sources

ARTICLE 10. SERIES REQUIRED ELECTRONICS

10.1. Series Scrutineering Data System

- 10.1.1. Cars must be equipped with the global TCR spec Aim Evo5 system as sold by Memotec (www.me-mo-tec.com) .
- Cars must use and install the Memotec harness as supplied.
 - Power lead shall remain on as long as the master kill is switch is on.
 - Entrant is responsible for the proper installation, operation, and safe handling of all Series Scrutineering Data System Components
 - Series Scrutineering Logger must be fully functional when on-track
 - SD Cards are property of IMSA and shall be distributed once load-in is complete
 - Configurations (CAN, Logger, etc) must be used as delivered for the specific car model

10.1.2. System Parts List

Memotec Part #	Description	Qty
evo5-TCR	Complete TCR Datalogger Kit	1
varies	Memotec Harness per manufacturer	1
	Individual components	
Evo5logger	evo5 Logger without accessories	1
evo5-KBSDL	Wiring harness evo5, 37 pin, SDL	1
GPS-08L	GPS-08 with 4000 mm cable length	1
M21E003	USB-Adapter 719 4-p - Mini USB	1
M-HGTM	Holder kit for SDL Logger	1
V26Z943	Pressure sensor 0 - 3 bar absolute, 711	1
M13ZL11S	IR Receiver, 711	1
M22-FIA	CAN Connection cable, SDL, FIA, DTM06-6S	1

10.1.3. Series Scrutineering Data System collection requirements are:

- Entrants must present all series mandated data collection media to the IMSA Technical Inspection trailer within thirty (30) minutes of the completion of each session.
 - For sessions within one (1) hour of one another, Data shall not be required to present after the first session
- Failure to present media within the specified window may result in a penalty including (but not limited to) a stop and hold plus five (5) minutes.

10.2. Safety Light System

- 10.2.1. Cars must be equipped with the Delphi Yellow Light Kit to indicate active flag status.
- a. The Kit contains the following components:
 - i. Yellow Indicator Light
 - ii. Mounting Bracket
 - iii. Antenna
 - iv. Wiring Loom and Instructions
- 10.2.2. The Safety Light system must be installed and functioning during on-track activity.
- a. The Yellow Indicator Light must be prominently installed within the cockpit, in clear line of sight of the driver.
 - b. Antenna Installation: The supplied antenna must be mounted:
 - i. On the Car roof
 - ii. Away from other antennae
 - iii. Following the diagram below (a ground plane is not required):

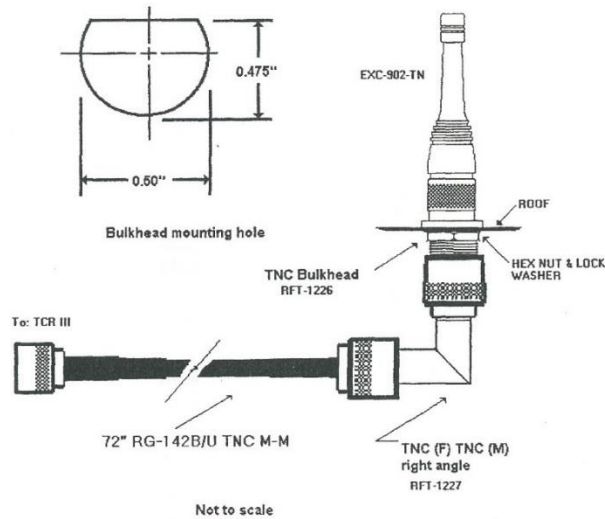

- c. Wiring Loom Installation: The Wiring Loom has a flying lead input for +12 VDC and Ground to interface with additional wiring referenced in the installation instructions.
 - i. Entrants must supply additional wiring as required.

- 10.2.3. An activating receiver is available from IMSA during Safety Checks at each Event and remains the property of IMSA.
- a. Entrants must surrender the receiver when required by IMSA.
 - b. A lost or damaged receiver is subject to a replacement fee referenced in the IMSA Accessories form

10.3. Driver ID System

- 10.3.1. Cars must be equipped with the Motec Driver ID Module # RG OTC
- a. Available for purchase through Motec
- 10.3.2. Entrant must supply Driver ID Plugs
- 10.3.3. Female Driver ID plug(s), (i.e. Driver #1 through Driver #5) may be installed inside the Car cockpit or attached to the individual Drivers' helmets.
- a. Alternative installations must be approved by IMSA.
- 10.3.4. Transponder and plugs must be tested and operate to the satisfaction of the Timing and Scoring Officials.

10.4. X2 Transponder System

- 10.4.1. Installation of the X2 system must be in accordance with the IMSA Approved, Manufacturer submitted Series Electronics Declaration Form added to the Technical Credential.
 - a. Series Electronics Declaration Form is available from the respective Manufacturer Partner.
- 10.4.2. Cars must be equipped with the X2 Transponder System Kit
 - a. Kit contains the following components:
 - i. X2 Transponder
 - ii. Isolation Mounts
 - b. Entrant must supply the following additional item(s):
 - i. X2 Transponder Mounting Bracket (available for purchase as listed in the IMSA Accessories Order Form).
 - ii. M4 Socket Head Cap Screw and Washer.
- 10.4.3. X2 transponder may be purchased via the IMSA Accessories Order Form.:
- 10.4.4. Transponder and plugs must be tested and operate to the satisfaction of the Timing and Scoring Officials.
- 10.4.5. Transponder consumes less than 300 mA (10-15 VDC), and must:
 - a. Be a fused, 12-volt DC configuration
 - b. Meet the specifications defined by ISO 7637

10.5. Leader Light System

- 10.5.1. Cars must be equipped with LED leader light panels as follows:
 - a. Motec Leader Light Panels # PV0091
 - b. Motec Harness
- 10.5.2. Leader light system must be installed and functioning during the Event
 - a. System must be installed in accordance the Manufacturer submitted, IMSA Approved, Series Electronics Declaration Form
 - b. Series Electronics Declaration Form is available from the respective Manufacturer Partner.
- 10.5.3. IMSA Leader Lights are available from Motec USA (https://www.milspecwiring.com/IMSA-Michelin-Pilot-Challenge_c_937.html)
- 10.5.4. Leader Lights consume less than 4.5 A (10-15 VDC), and must:
 - i. Be a fused, 12-volt DC configuration
 - ii. Meet the specifications defined by ISO 7637

10.6. Back-lit Panel

Not Applicable

10.7. Pro-Am Light

Not Applicable

10.8. In-Car Camera

Not Applicable

ARTICLE 11. REFUELING SYSTEM

11.1. Fuel Transfer

- 11.1.1. Fuel may be transferred from the autonomous supply tank to the Car using the equipment and methods defined in this Article.
- a. Approved equipment as defined herein must be:
 - i. Unmodified.
 - ii. Installed and operational.
 - b. Approved method:
 - i. Gravity.
- 11.1.2. Fuel transferred to the autonomous supply tank must be delivered by means of a hose fitted with a self-sealing connector (e.g. dry break, cam-lock) connected to the autonomous supply tank.

11.2. Pit Tank

- 11.2.1. Construction of the Autonomous Supply Tank must:
- a. Comply with FIA Appendix J Drawing n° 252-7 with the exception of the top plate shape and dimensions.
 - b. Have a simple cylindrical internal shape.
 - c. Not have any additional internal parts that could improve flow.
 - d. Have a tolerance on bottom flatness of less than 3 mm inside the tank.
 - e. Have the flow restrictor top face at the level of the internal surface of the bottom of the supply tank.
- 11.2.2. Refueling tank height is measured from the top surface of the vessel, not including vent, cover plate or fasteners, at a distance of 1.25 meters from the outermost face of the pit wall
- 11.2.3. The required refueling tank height is 2.0 meters with a tolerance of +0/-1.0 cm.
- 11.2.4. Once inspected by an IMSA Official the Autonomous Supply Tank, Trolley, Peripheral Connections, and Restrictor must remain as inspected with all IMSA seals intact until the conclusion of the Race or upon an approved retirement via TIMS.

11.3. Peripheral Connections

- 11.3.1. Tanks must be equipped with the IMSA-specified peripheral connections between the tank outlet and the refueling hose.
- a. Parts must be purchased from RPXpress:

Part Number	Part	Description
BSR-FR FN40	Outlet Flange	Bottom Tank 12-bolt housing
ATL-TF 147	12-Bolt Gasket	
BSR.FR.R.35GOLD	35.0mm Restrictor	Upper Restrictor (for positive seal to Elbow)
BSR-FR 1981	Bottom 80 deg. Elbow	Female Camlock x 2" Male
BSR.P.5K56.SS	Restrictor Housing	Deadman Outlet, 2" Male to 1 1/2" Camlock
BSR.P.5K.RPX.SS	Hose Coupler	1.5" OD barb to Deadman outlet
1 Deadman Valve:		
BSR-FR-R003	Deadman Valve (new design)	Stainless Deadman Valve
BSR-FR-R002	Deadman Valve (old design)	Brass Deadman Valve

a. Refueling System Assembly Illustration:

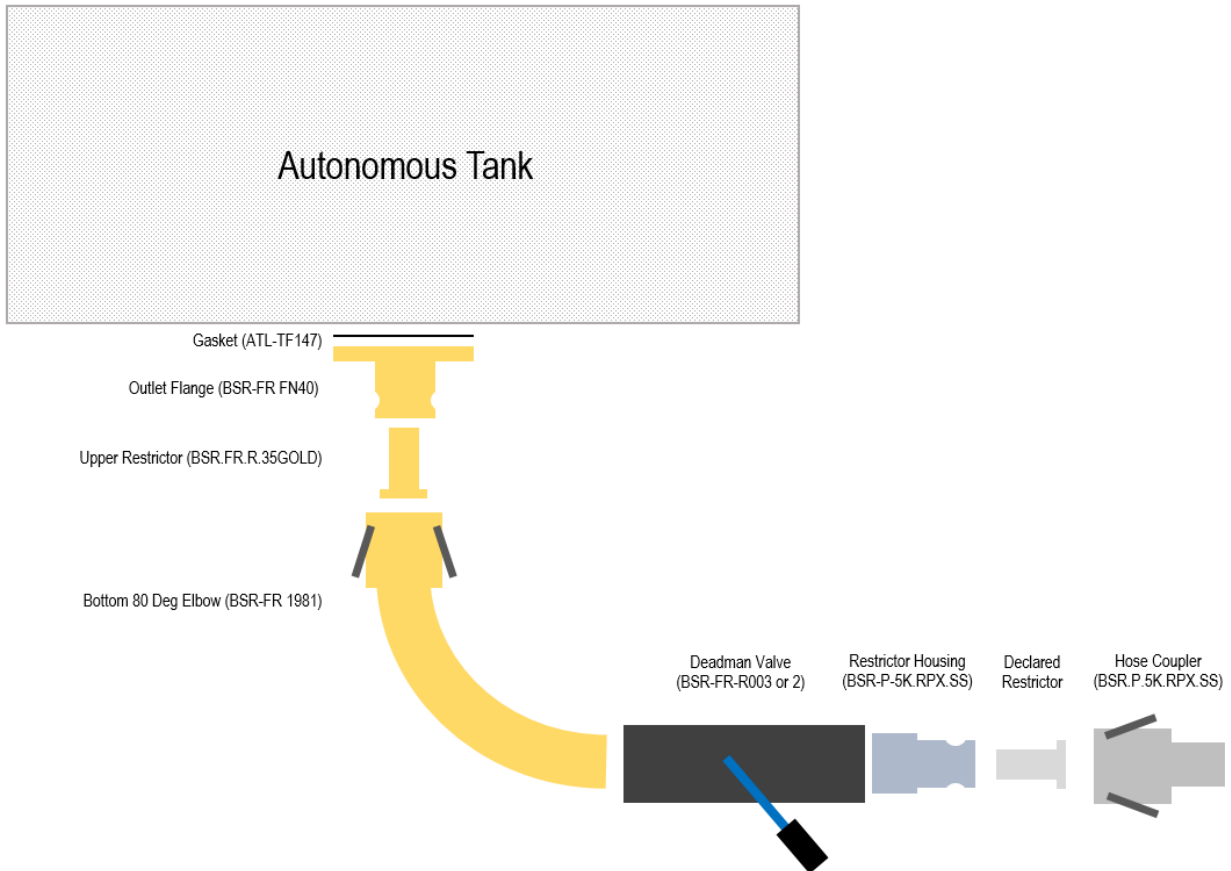

- 11.3.2. Deadman valve and bottom 80 deg. elbow assembly must be securely braced to remain attached to the tank in the event of an incident.
 - a. Mechanisms preventing normal operation of the deadman valve are prohibited.
 - b. Any configuration of the IMSA-mandated design intended to decrease the minimum refueling time below the minimum time listed in the class specific BoP table is prohibited.
 - c. During fuel delivery operations, the deadman valve must be fully open such that the throat of the ball is aligned axially with the outlet of the deadman valve body with the actuation handle fully extended.
 - i. Adjustment mechanisms will be sealed by IMSA.
- 11.3.3. During refueling the air vent outlet must be connected using an appropriate coupling to the tank.
- 11.3.4. A sight glass may be installed to the outside of the supply tank, and must be equipped with isolating valves mounted as close as possible to the tank.

11.4. Refueling Hose

- 11.4.1. Refueling/vent hoses must have one end equipped with a self-sealing connector to fit the autonomous supply tank outlet.
- 11.4.2. Refueling/vent hoses may be protected for the sole purpose of resisting abrasion damage.
 - a. Cover must be easily removable by means of full-length Velcro or zipper.
 - b. Cover must be non-reflective
- 11.4.3. Hose maximum inside diameter
 - a. Dual-Port systems must be less than 1.5 inches for all hoses.
 - b. Single-Port (coaxial) systems must be less than 1.5 inches for Refueling Hose and less than 75.0 mm for the vent hose

11.4.4. Refueling hose minimum length must be greater than 4.0 m

- a. Minimum length is measured from the most distant plane of the dry break/fuel probe to the most distant plane of the Hose Coupler.

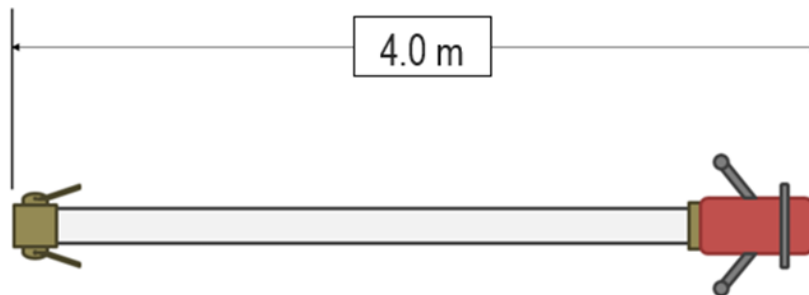

11.5. Tank Support Stand

11.5.1. The tank must be attached to one of the following:

- a. To a trolley meeting the following requirements:
- i. All tower components must be assembled without any degree of freedom in relation to the trolley.
 - ii. Have a surface area greater than two (2) square meters.
 - iii. Utilize four (4) self-braking casters.
 - iv. Be ballasted with a weight exceeding that of the tank when filled with fuel.
- b. Scissor style (X-brace) stand

11.5.2. A system for weighing the fuel may be applied by:

- a. Placing a weighing plate underneath tank.
b. Ensuring the characteristics set out above are respected.

11.6. Boom

Not Applicable

11.7. Refueling Restrictor

11.7.1. During refueling, all fuel entering the Car must pass through the refueling restrictor.

11.7.2. Refueling Restrictor must meet the following criteria:

- a. Material must be an aluminum alloy.
b. Must comply with the IMSA Fuel Restrictor Part Drawing at the end of these Technical Regulations

11.7.3. IMSA may adjust the refueling rig and the minimum refueling time listed in the class specific Balance of Performance Tables and associated Technical Bulletins.

- a. Refueling restrictors may be purchased from RPXpress (Phone: +1-828-428-0820 Email: lmcelwain@rpxpress.com).
b. At each Event, every Entrant must declare their chosen diameter, limited to 22 to 34 mm in 0.25 mm increments, by completing the [IMSA Refueling Restrictor Declaration Form](#) prior to 5:00 PM Local Time the day before race day.
c. IMSA may utilize the following scrutineering inspection methods to check minimum refueling times:
- i. Vehicle data system.
 - ii. Video review.
 - iii. Minimum Refueling Time Audit (Reference: SRR 37.5).

11.7.4. Refueling Restrictors are sealed by IMSA Technical Officials.

- a. Entrants must receive written approval from IMSA to remove seals following inspection, and seals must be replaced by IMSA Technical Officials prior to on-track activity.
- b. The following bolts must be drilled for safety-wire sealing of the restrictor
 - i. Two (2) adjacent Bolt heads of the Restrictor Housing
 - ii. Two (2) Hinge Bolts (threaded section) of the Outlet Pipe Cam Lock
 - iii. Two (2) Lock Lever Arms of the Refueling Hose Cam Lock
 - iv. A 0.125 inch hole must be drilled in the two female camlock levers on the bottom 80 deg. elbow assembly 0.5 inches below pin in the locations indicated in yellow on the diagram below:

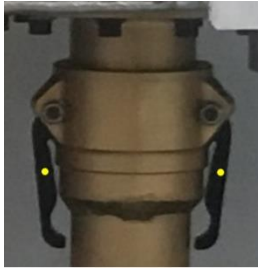

11.8. Level Sensor System

Not Applicable

